

Serie
Celosías

Lamas Alpha

Paso 90 = 10 lamas x metro
 Paso 100 = 9 lamas x metro
 Paso 120 = 8 lamas x metro
 Paso 135 = 7 lamas x metro

Lamas Kappa

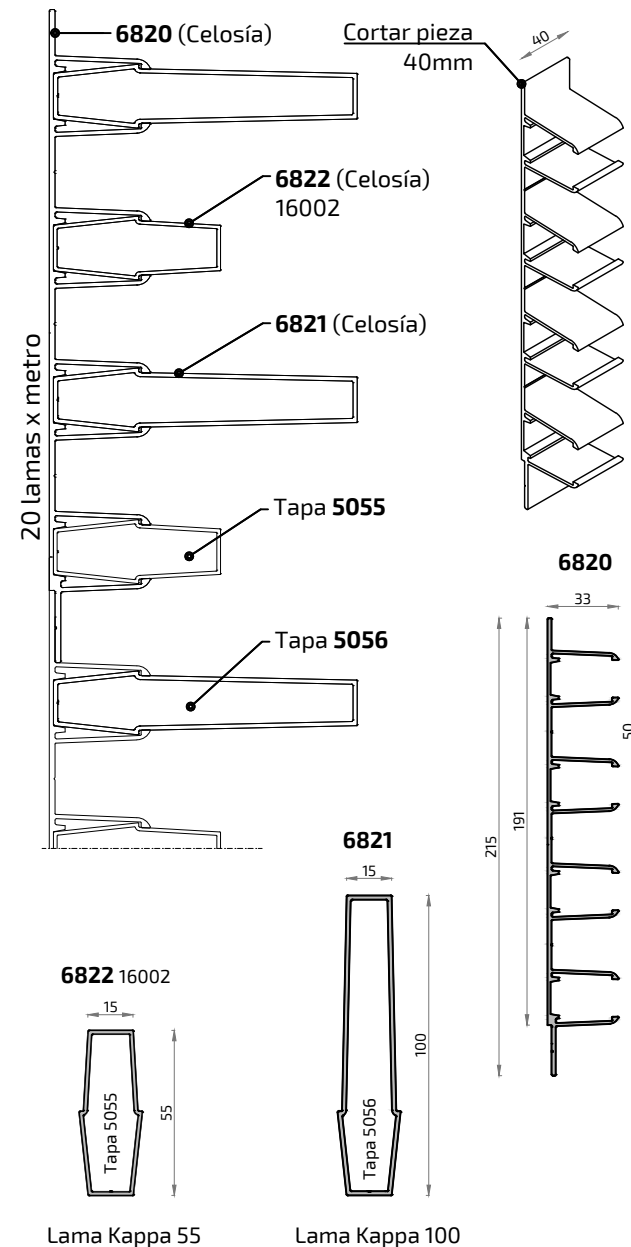
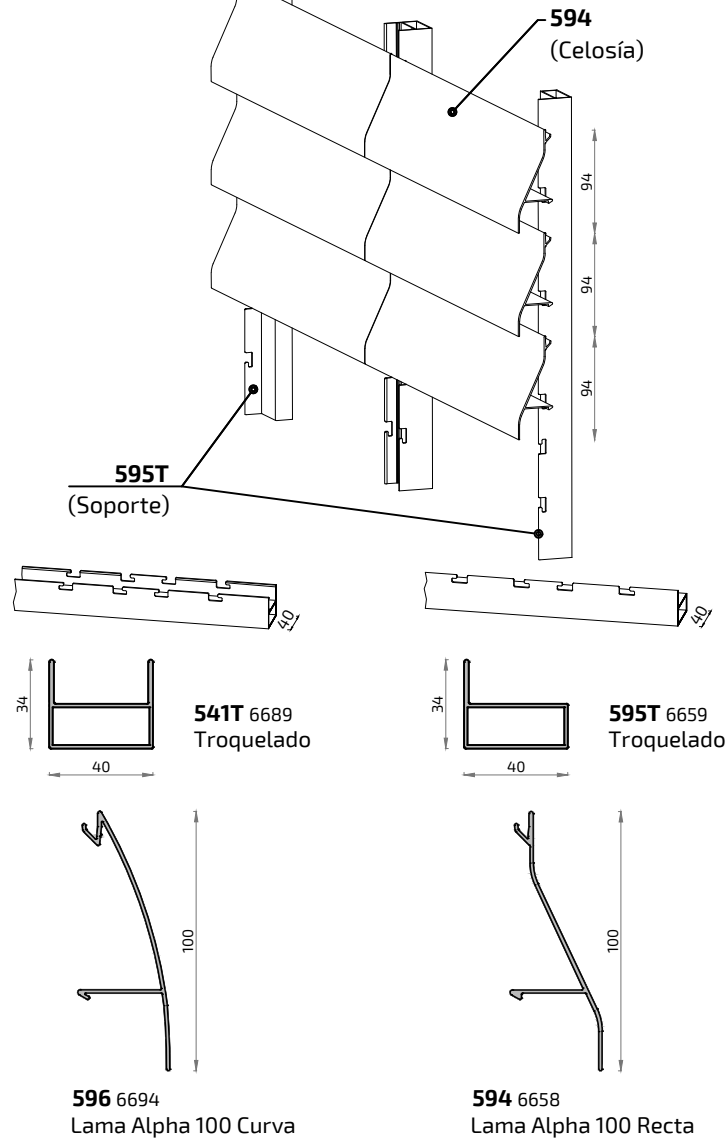
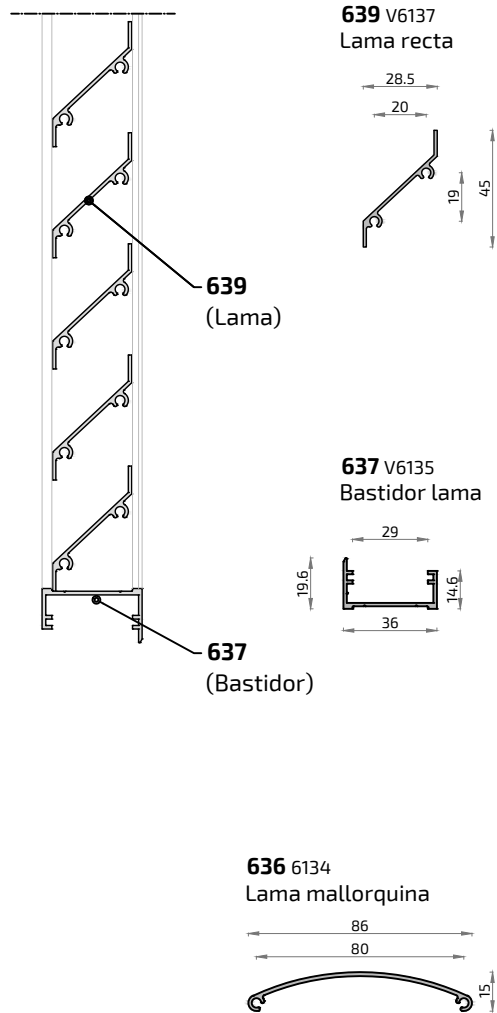

CON PIEZA DE SOPORTE **5058**

LAMA DELTA 250
(Celosía 16080 + Soporte 5061)
o (Celosía 16080 + Soporte 5058)

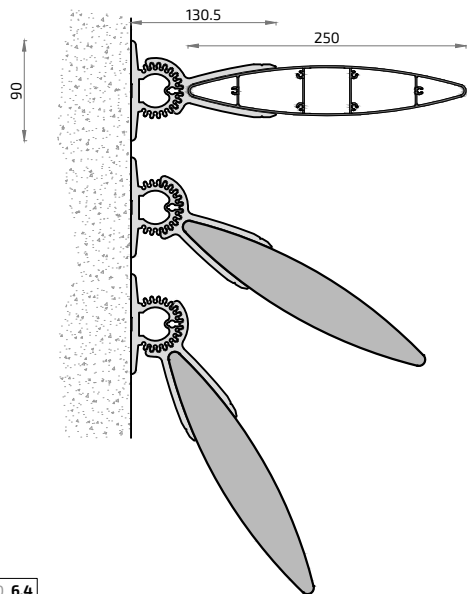
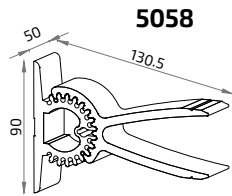
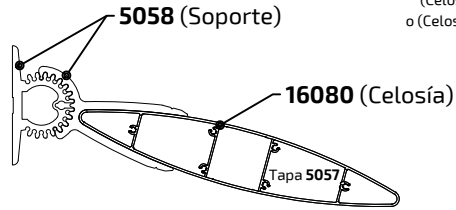

CON PIEZA DE SOPORTE **5060** (PARA CELOSÍA DE 250 Y 200 mm), Y SOPORTE **5060** (PARA CELOSÍA DE 120 mm)

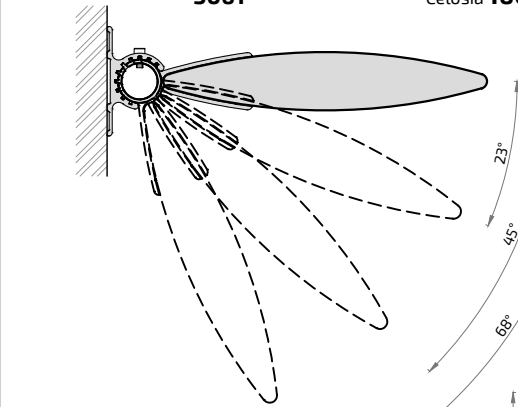
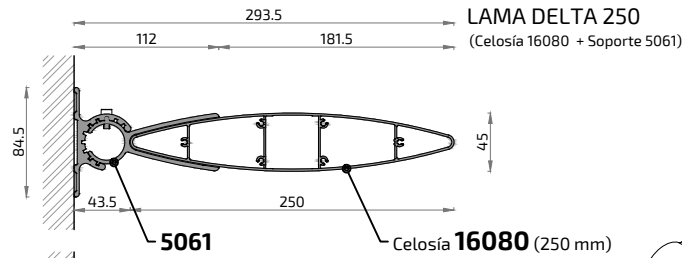

Tapa 5062

Tapa 5063

Tapa 5057

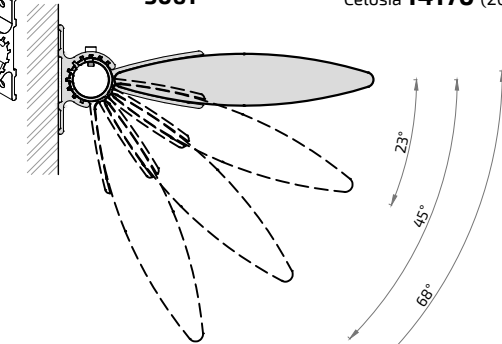
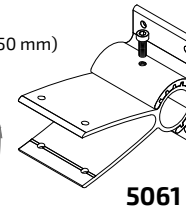
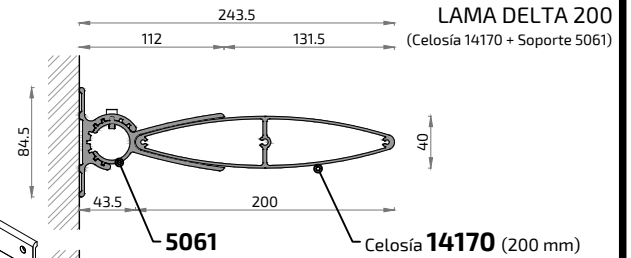

LAMA DELTA 120
(Celosía 16561 + Soporte 5060)

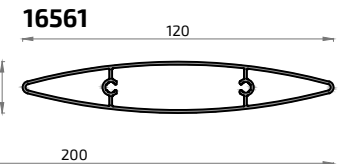
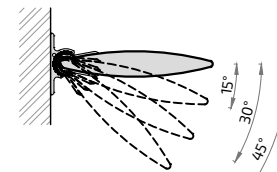
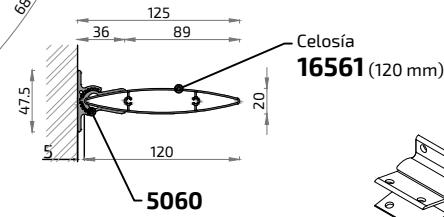

14170

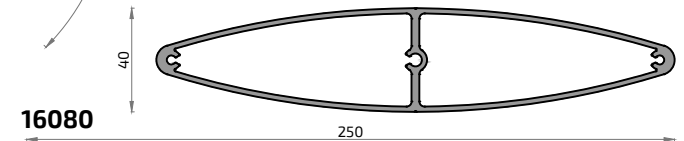

CARACTERÍSTICAS TÉCNICAS

Sistema de Parasol con celosía ovalada de 210 mm (ref.:18429)

- Bulón de acople a sistema de acero inoxidable
- Doble eje retractil
- Varilla de conexión de 8 mm de diámetro también en inoxidable
- Testeros en aluminio (Lacado o anodizado) de 2 mm
- Casquillo de fricción para los porta-testeros
- Lamas de hasta 3 m. (largo de lama) Se recomienda un dispositivo de Orientación cada 15 lamas
- Motor carrera 300 mm
Motor con conexión simple (Válido para un módulo)
Motor con conexión doble (Válido para dos módulos)



Perfiles

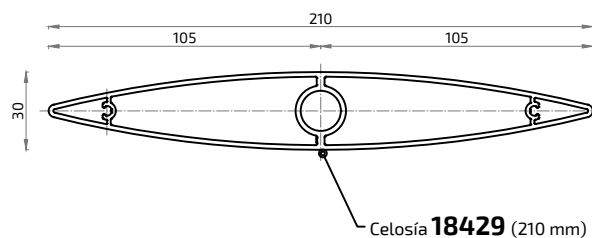

Accesorios

| | | | | | | | | | | |
|------------------------------------|------------------------------------|--------------------------------------|---|---------------------------------------|---|------------------------------------|--|--|-------------------------------------|---------------------------------------|
| 5538 Kit Híbrido L210 Dcha. | 5539 Kit Híbrido L210 Izda. | 5540 Tapa Híbrido (210) Motor | 5541 Varilla Transmisión Ø8 x 3m | 5542 Motor C300mm para varilla | 5543 Motor C300 doble para varilla | 5544 Emisor radio 2 canales | 5545 Receptor radio para pulsador | 5546 Arandelas lamas verticales | 5547 Cierre superpuesto L210 | 5548 Cierre integrado Top L210 |
|------------------------------------|------------------------------------|--------------------------------------|---|---------------------------------------|---|------------------------------------|--|--|-------------------------------------|---------------------------------------|

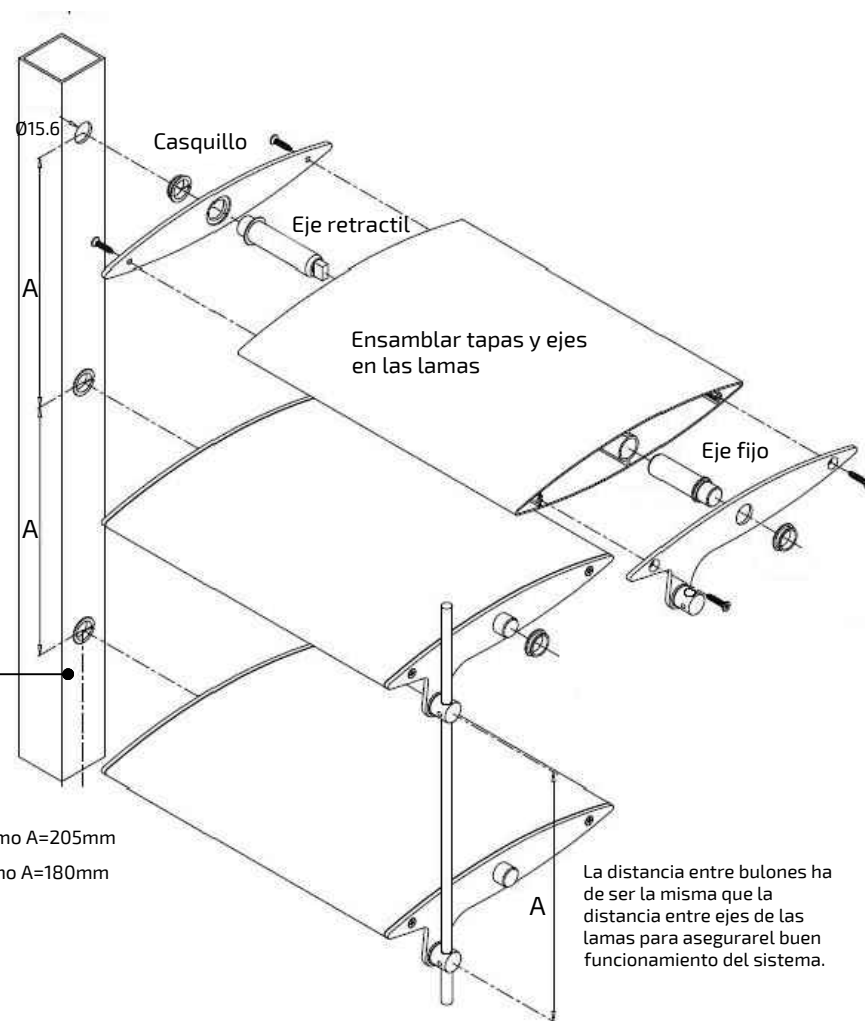

Lamas Delta

Celosías

Perfiles

16561

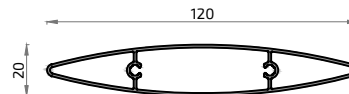

Accesorios

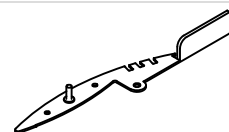

A21028

Mando lateral con bloqueo

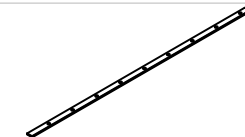

A21029

Pletina de 6 metros troquelada

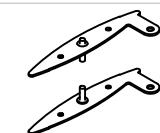

A21030

Tapas laterales con pivotes



A21031

Pieza pivote

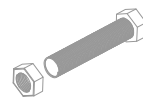

A21032

Tornillo fijación pletina

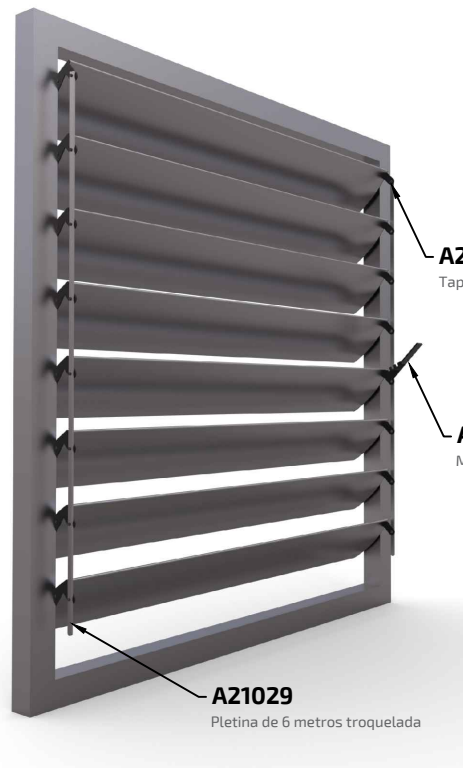

A21030

Tapas laterales con pivotes

A21028

Mando lateral con bloqueo

A21029

Pletina de 6 metros troquelada

Posición de bloqueo en el mando lateral



Posición 1

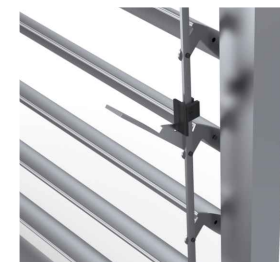

Posición 2



Posición 3