

Especificaciones Técnicas

Carpintería practicable con Rotura de Puente Térmico

Cámara Europea

Junta abierta con Junta Central

Sección de Marco..... 65 mm

Sección de Hoja..... 59,5 mm

Acrilamiento Hoja..... 2 - 22 mm

Acrilamiento Cerco..... 9 - 43 mm } Incluyen Juntas Acristalar

junquillos de altura 22 mm

Peso Máximo por : Hoja Practicable: **120 kg** (1)

Hoja Oscilo Batiente: **100 kg** (1)

Medidas Máximas por Hoja para todas las aperturas :

1700 mm x 2500 mm (1)

370 mm x 400 mm (1)

(1) Consultar rangos de aplicación con nuestro Departamento Técnico

Clasificación Obtenida:

Permeabilidad al aire*	CLASE	4
Estanqueidad al agua*	CLASE	E2250
Resistencia al viento*	CLASE	C5
<hr/>		
Transmitancia térmica** Uw		1.6 W/m² K
Transmitancia térmica con HQ ** Uw		1.5 W/m² K
Transmitancia térmica Uf (Nudo lateral)^		2.4 W/m² K
Transmitancia térmica Uf con "HQ" ^		2.1 W/m² K
Aislamiento Acústico***		44 (-1;-4) dB

* Ventana de 2 hojas de 1230 x 1480 mm

** Ventana de 2 hojas de 1600 x 2335 mm; vidrio Ug: 1 W/m² K - UNE-EN ISO 10077-1:2010

*** Ventana de 2 hojas de 1230 x 1480 mm; vidrio 4+4/10/5+5 Silence - UNE-EN ISO 10140-2:2011

^ Según normativa UNE-EN ISO 10077-2:2020

Posibilidades de Apertura

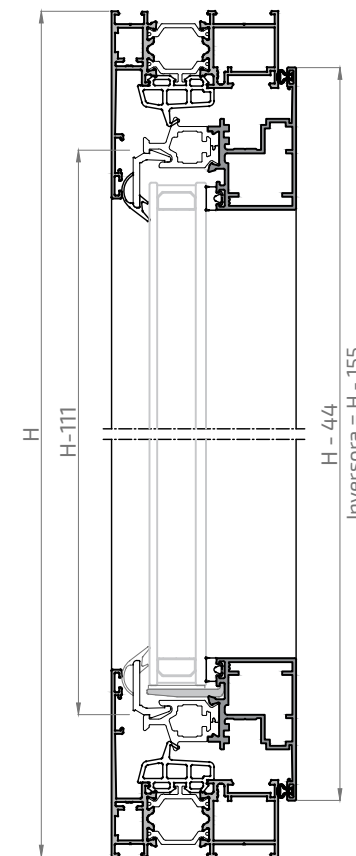
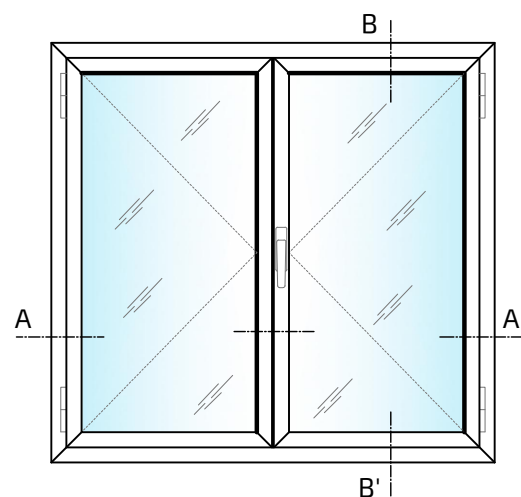
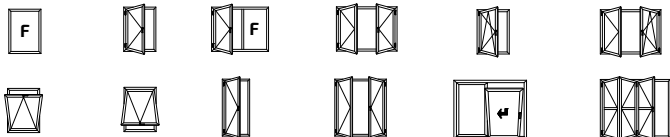

Sección B-B'

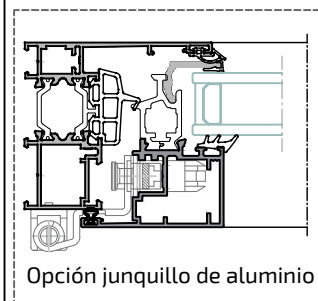

Opción junquillo de aluminio

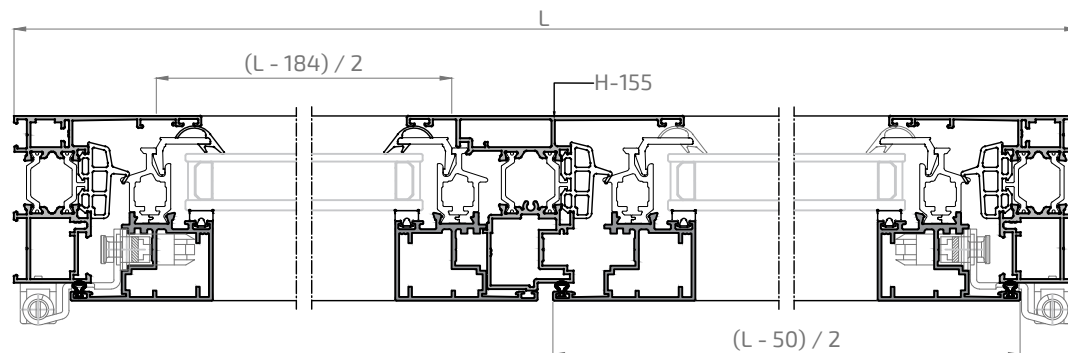

Sección A-A'

Los ensayos de las ventanas realizados por el grupo ALUGOM, que son cedidos para la obtención del marcado CE por parte del cliente, se han realizado con los perfiles y accesorios específicos y concretos propuestos por el grupo ALUGOM que figuran en los manuales de fabricación de cada serie. Para más información consultar con el departamento técnico del grupo ALUGOM.

alg 65 ÓPTIMA HS C16

16779L
Cercos 30 mm alg 65 HS

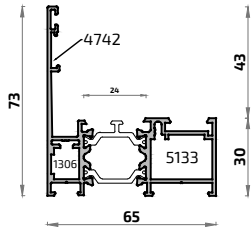

8190L **NO STOCK**
Cercos solape 30 mm alg 65 HS

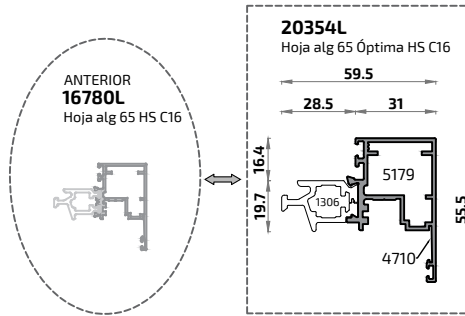
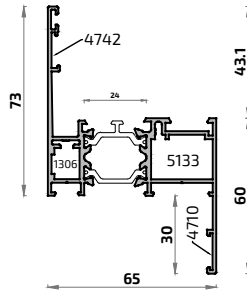

16781L
Acople inversora alg 65 HS C16

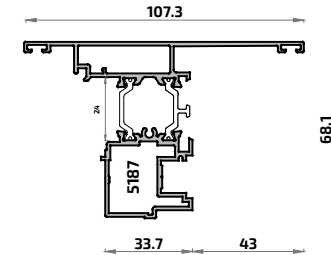

16767L
Pilastra Asimétrica 30 mm alg 65 HS

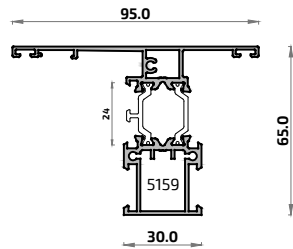

16768L
Pilastra Simétrica 50 alg 65 HS

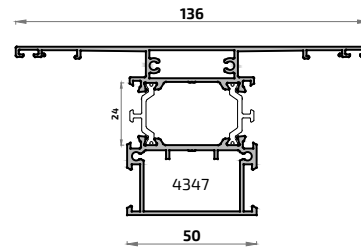

717 1207
Acople junquillo ALG 65 HS

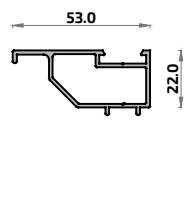

20271
Junquillo alg hoja oculta

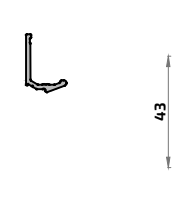

20218
Junquillo largo 36 mm

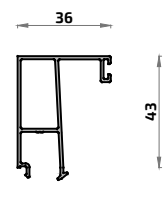

20217
Junquillo largo 28 mm

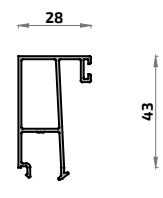

20318
Junquillo largo 21,5 mm

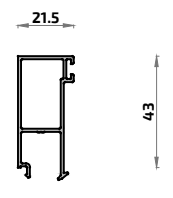

20334
Junquillo largo 14,5 mm

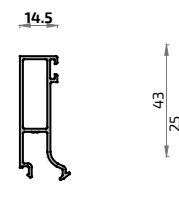

21087
Junquillo largo 10,5 mm

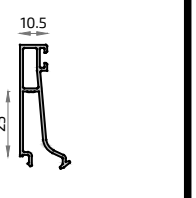

18897L
Esquinero regulable hembra 65

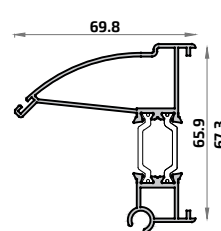

18898L
Esquinero regulable macho 65

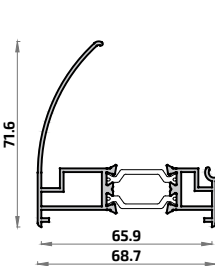

10006M
Esquinero 90° Curvo

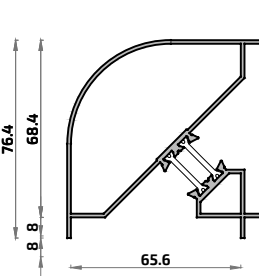

18215L
Esquinero 90° Recto

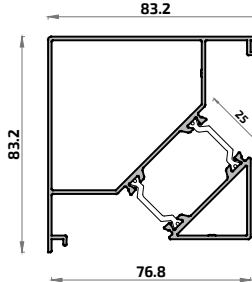

16319L
Condensación 65 mm alg 65

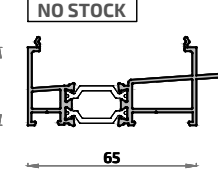

20075
Unión Cercos alg

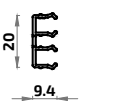

20093
Junta de Cercos Garganta alg



10077
Reductor de vidrio 10 mm



10078
Reductor de vidrio 12 mm



9829
Reductor de vidrio 18 mm



8428
Vierteaguas



16321
Solapa clip 30mm

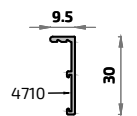

16322
Solapa clip 45mm

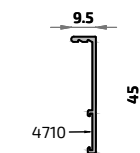

16323
Solapa clip 65mm

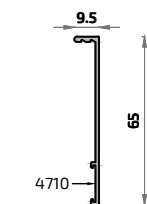

8482L
Unión de cercos alg 65

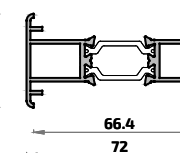

NO STOCK FUERA DE STOCK Consultar plazo y condiciones de entrega

Detalles Técnicos
2 Accesorios

alg 65 ÓPTIMA HS C16

Cremonas y Manillas	5079 Manilla PREMIUM	5080 Manilla PREMIUM c/lave	5183 Manilla BÁSICA C/7 c/lave	5191 Manilla KORA C/7	5389 Manilla TOULON C/7	5398 Manilla ATLANTA C/7	5583 Manilla WONDER C/7 derecha	5584 Manilla WONDER C/7 izquierda	Escuadras	5133 Escuadra cerco	5134 Escuadra hoja	5179 Escuadra hoja HS	1306 Escuadra exterior	4742 Escuadra Cerco y Hoja	4710 Escuadra alineam. 14 mm.	Bisagras	5480 Bisagra alg Canal 16	
	4012 Clip guía	5178 Solera 70 mm	4078 Pieza sujeción junquillo curvo	5425 Escuadra junquillos curvos	1301 Calzo acristalamiento 40 mm	5122 Pieza soporte clip plano	5121 Pieza soporte clip exterior	5120 Pieza soporte clip interior		A23178 Motor VARIA SLIM CADENA	Tapas	5187 Tapa inversora alg65 C16HS	4994 Tapa rígida canal	4337 Embellec. salida aguas c/membr.	4035 Embellec. salida aguas		Termo Perfiles HQ	5088 [B] (10 x 10,5)
Varios	5116 [TS] (24 x 35,5)	5090 [D](19 x 13)	5109 [R] (17 x 14,5)	5097 Banda aislante cerco 5 x 26	Tacos	5159 Taco pilastra 30	4347 Taco pilastra 50	Juntas	5018 Junquillo coextrusión	A22020 Junta cerco HS		A22021 Junta Junquillo HS	5073 Junta central	5180 Refuerzo Junta central HS	5581 Junta central celular alg 65 HS	A21022 Ángulo Vulcanizado alg 65 HS		5105 Ángulo vulcanizado junta central
	5529 Junta perimetral espuma	1311 Junta Interna Vidrio 2,4 mm	1312 Junta Interna Vidrio 3,4 mm	1313 Junta Interna Vidrio 4,4 mm		1314 Junta Interna Vidrio 6,4 mm	1315 Junta Interna Vidrio 8,4 mm		1316 Junta Interna Vidrio 10,4 mm	1361 Junta Interna Vidrio 11,4 mm	1317 Junta Interna Vidrio 12,4 mm	1362 Junta Interna Vidrio 13,4 mm	1318 Junta Interna Vidrio 14,4 mm	5194 Junta interior acristalamiento de 2 mm	1337 Junta interior acristalamiento de 3 mm	1338 Junta interior acristalamiento de 4 mm	4089 Junta interior acristalamiento de 5 a 6 mm	4091 Junta interior acristalamiento de 7 a 8 mm
5155 Adhesivo Poliuretano																		



- Útiles**
- 5169 Útil alg C16
 - 5112 Útil sistema alg
 - 5525 Útil alg C16 + HS
 - 5015 Plantilla Escuadra A. Exterior
 - 4729 Bobina Pletina Poliamida
 - A23104 Útil alg VISTA y HS

- Fresas**
- 5125 Fresa Cerco alg 65 Óptima
 - 5126 Fresa Hoja alg 65 Óptima
 - 5176 Fresa Hoja alg 65 Óptima
 - 5198 Fresa Cerco alg 65 HS

- Varios**
- 5499 Tornillo C16 B11 3,9x25 mm Punta Broca
 - 5500 Tornillo C16 B2 3,9x16 mm Punta Broca
 - 5501 Tornillo C16 M2 M4x13 mm Punta Broca

Representación gráfica termo perfiles

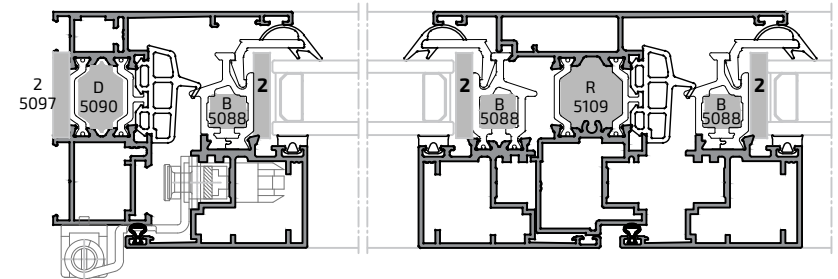

HERRAJE BÁSICO CANAL 16

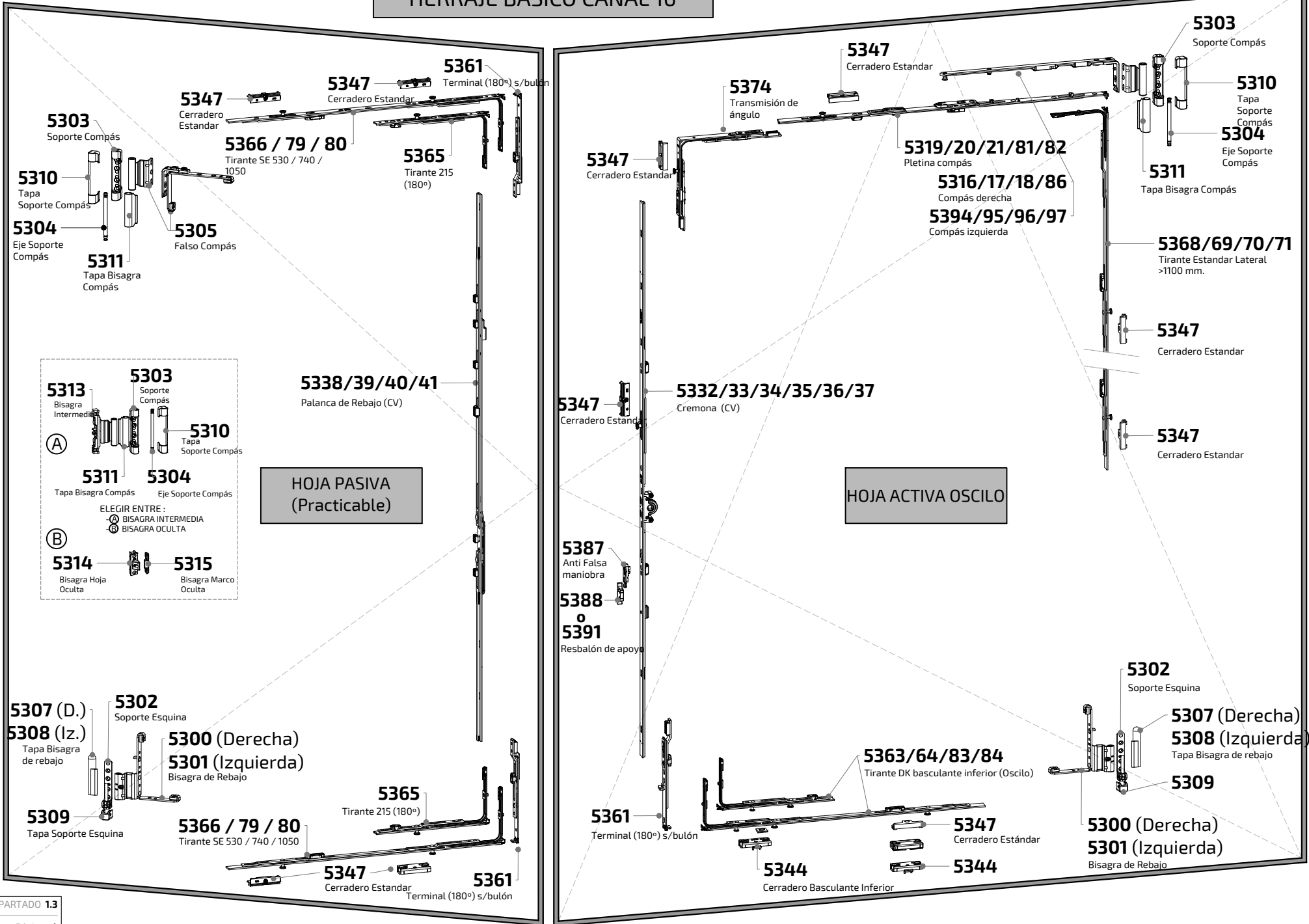









Juntas Exteriores
 A23019

 4057

 4850

Tabla Acristalamiento Fijo
 alg 65 ÓPTIMA HS C16

Juntas INTERIORES de acristalamiento

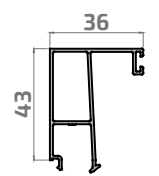
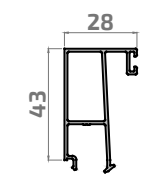
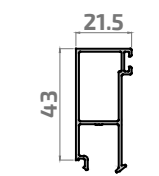
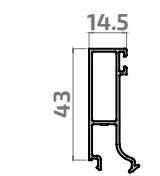
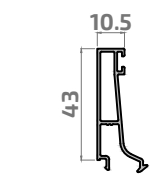
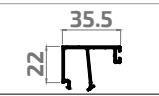
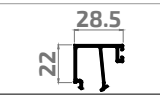
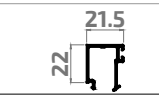
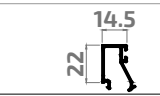
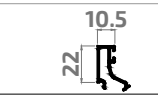
5194	1337	1338	4089	4091	5261
					
de 2 mm	de 3 mm	de 4 mm	de 5 a 6 mm	de 7 a 8 mm	de 9 a 10 mm

ALTURA JUNQUILLO = 43 mm	36 mm	28 mm	21,5 mm	14,5 mm	10,5 mm
PERFILES	20218	20217	20318	20334	20317
CERCOS: 16779L 8190L					
PILASTRAS: 16768L 16767L					
ALTURA JUNQUILLO = 22 mm	35,5 mm	28,5 mm	21,5 mm	14,5 mm	10,5 mm
PERFILES	8820	8625	16866	8825	8827
PILAISTRA: 16767L					
VIDRIO DE 12 mm	●				
VIDRIO DE 13 mm	●				
VIDRIO DE 14 mm	●				
VIDRIO DE 15 mm	●				
VIDRIO DE 16 mm	●				
VIDRIO DE 17 mm	●				
VIDRIO DE 18 mm	●				
VIDRIO DE 19 mm	●				
VIDRIO DE 20 mm		●			
VIDRIO DE 21 mm		●			
VIDRIO DE 22 mm		●			
VIDRIO DE 23 mm		●			
VIDRIO DE 24 mm		●			
VIDRIO DE 25 mm		●			
VIDRIO DE 26 mm		●			
VIDRIO DE 27 mm			●		
VIDRIO DE 28 mm			●		
VIDRIO DE 29 mm			●		
VIDRIO DE 30 mm			●		
VIDRIO DE 31 mm			●		
VIDRIO DE 32 mm			●		
VIDRIO DE 33 mm			●		
VIDRIO DE 34 mm				●	
VIDRIO DE 35 mm				●	
VIDRIO DE 36 mm				●	
VIDRIO DE 37 mm				●	
VIDRIO DE 38 mm				●	
VIDRIO DE 39 mm				●	
VIDRIO DE 40 mm					●
VIDRIO DE 41 mm					●
VIDRIO DE 42 mm					●
VIDRIO DE 43 mm					●
VIDRIO DE 44 mm					●
VIDRIO DE 45 mm					●

La Tabla superior de cálculo del espesor de vidrio para esta serie se ha estudiado con junta interior y exterior de acristalamiento. Si se quisiera acristalar con silicona por la parte interior, se podría ganar algo de medida.

TABLA DE ACRISTALAMIENTO HOJAS
CON JUNTA INTERIOR DE CLIP

CON JUNTA INTERIOR
PARA HUECO DE 28 MM

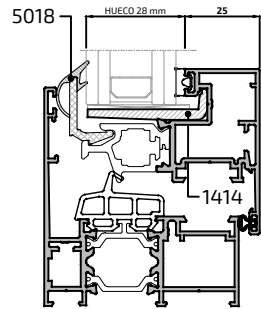

REDUCTOR DE VIDRIO + JUNTA
INTERIOR
PARA HUECO DE 28 MM

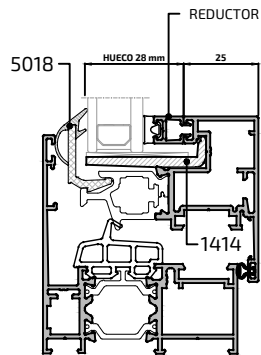

JUNTAS INTERIORES DE ACRISTALAMIENTO							
	1311	1312	1313	1314	1315	1316	1361
SOLO CON JUNTA INTERIOR	Vidrios de (en mm)						
VIDRIO DE 26 mm	●						
VIDRIO DE 25 mm		●					
VIDRIO DE 24 mm			●				
VIDRIO DE 23 mm			●				
VIDRIO DE 22 mm				●			
VIDRIO DE 21 mm				●			
VIDRIO DE 20 mm					●		
VIDRIO DE 19 mm					●		
VIDRIO DE 18 mm						●	
VIDRIO DE 17 mm							●
VIDRIO DE 16 mm							●

JUNTAS INTERIORES DE ACRISTALAMIENTO							
	1311	1312	1313	1314	1315	1316	1361
SOLO CON JUNTA INTERIOR	Vidrios de (en mm)						
VIDRIO DE 16 mm	+						
VIDRIO DE 14 mm	+		+				
VIDRIO DE 12 mm			+	+			
VIDRIO DE 10 mm				+	+		
VIDRIO DE 8 mm	+				+	+	
VIDRIO DE 6 mm			+			+	
VIDRIO DE 4 mm				+			+